

Datasheet: SEN-3D-CAM MAGNETIC FIELD CAMERA

TRUE high-resolution and high-speed 3D magnetic camera

DESCRIPTION:

SEN-3D-CAM-CBL is the World's First True 3D Magnetic Field Camera with the smallest head ever.

The 3D Magnetic Camera features a compact chip positioned within its small head, making it the perfect tool for inline inspection applications and on production lines where space is essential. Its space-efficient design ensures seamless integration into tight work environments, enhancing its utility for critical tasks in various industries.

It simultaneously measures all three magnetic field components (Bx, By, Bz) using Senis proprietary 3D Hall technology. The camera provides comprehensive and accurate pictures of magnetic fields in three dimensions.

With a spatial resolution of 100 μm and a tiny measurement volume of 27 μm x 9 μm x 4 μm in each pixel, SEN-3D-CAM offers unprecedented precision in magnetic field measurement. This is particularly important if you need to measure complex fields with high field gradients. With 16,000 pixels, SEN-3D-CAM can acquire a full magnetic image within just 1 second, making it ideal for both inline and offline inspection of magnetic systems.

The direct output of SEN-3D-CAM is in 2D images, with all three field components accurately calibrated. These calibrated images are streamed through a USB-C connection, providing real-time data for analysis and visualization. In addition, the optional Senis 2D Vision Commander Software is available for more sophisticated magnetic image analysis, allowing for advanced magnetic data processing and interpretation.

Experience the future of magnetic field measurement with SEN-3D-CAM, the world's first true 3D magnetic field camera. With its unmatched precision, high acquisition rate, and advanced software options, SEN-3D-CAM is the ultimate tool for magnetic field analysis in research, industry, and beyond. Stay ahead of the curve and unlock new possibilities with SEN-3D-CAM today.

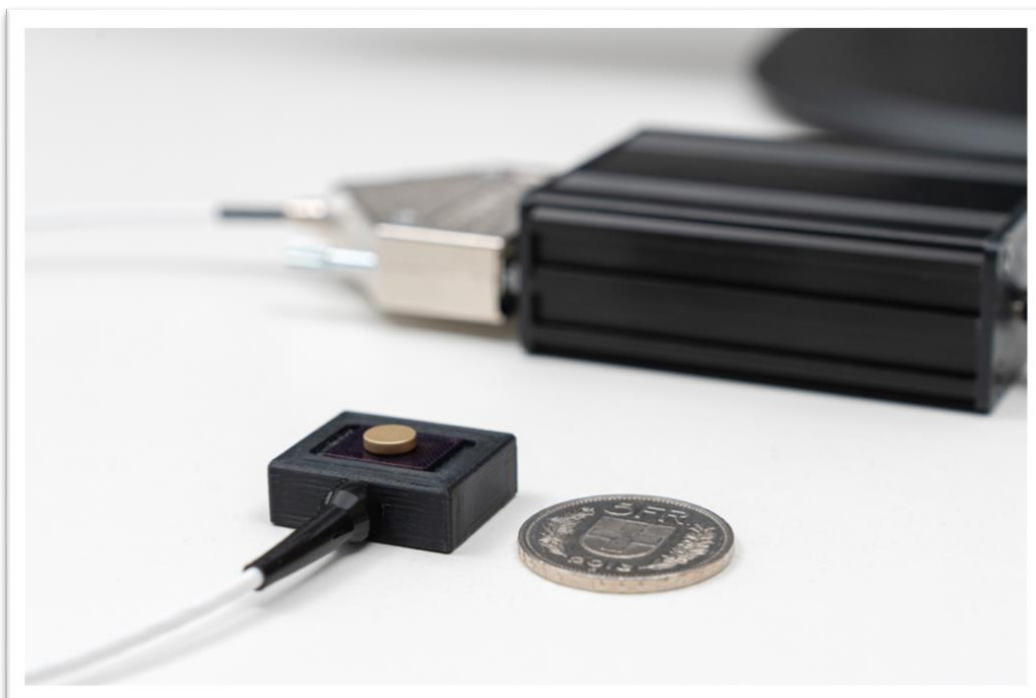

Figure 1: SENIS magnetic field camera SEN-3D-CAM with USB cable output

KEY FEATURES:

- Fast, true, and precise 3D magnetic field camera
- Compact head for easy installation into various application
- Measures all three 3 field components of a magnetic field (Bx, By, Bz)
- Very high magnetic and spatial resolution (16k pixels)
- World's smallest sensitive volume of $27\mu\text{m} \times 9\mu\text{m} \times 4\mu\text{m}$ in each pixel
- High image acquisition rate of 1 image/s



Figure 2: SEN-3D-CAM-CBL head with a sample

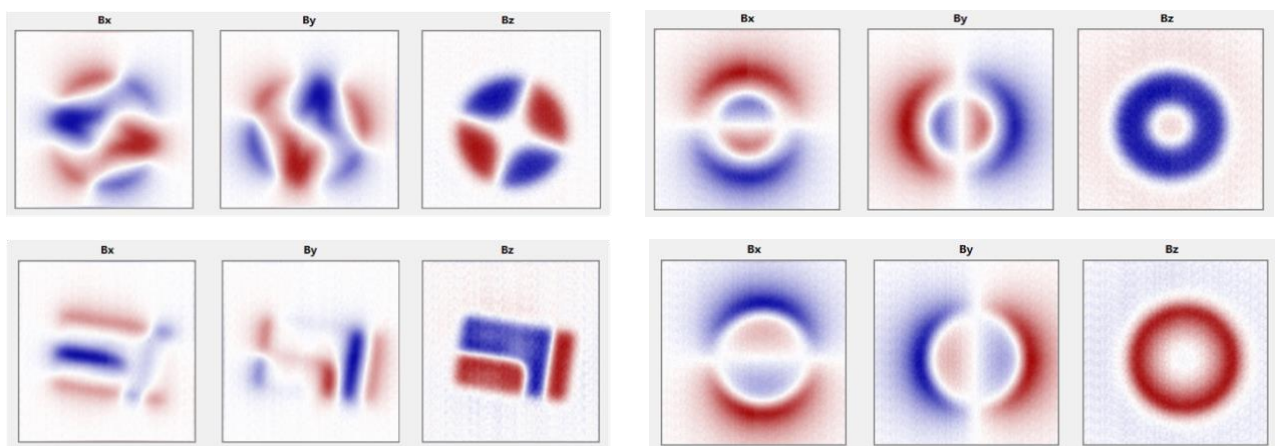

Figure 3: True 3-axis magnetic field measurements with SEN-3D-CAM-CBL

TYPICAL APPLICATIONS:

- Fast, true, and precise 3D magnetic field mapping
- Fast, true, and precise Inline Inspection
- Fast characterization and quality control of permanent magnets
- Development of magnet systems
- Application in laboratories and in production lines

SPECIFICATIONS:

Sensor	
Sensor Type	Senis 3D Hall
Data Output	Calibrated true Bx/By/Bz for each individual pixel
Image rate	1 image/s
Pixels	128x128, Field Sensitive Volume: 27µm x 9µm x 4µm in each pixel
Total Active Area	12.8x12.8mm
Software and Communication	
Supply Voltage	5V, through USB connector
Interface	USB 3.0 / RNDIS
Software (optional)	Senis 2D Vision Commander V1.3
Operating System (optional)	MS Windows 7 and later
Magnetic Field	
Calibration ranges	100mT and 500mT
Absolute accuracy	< 1% of full scale
Repeatability	< 0.2% of full scale
Digital resolution	12 bit
Non-orthogonality of magnetic axes	<0.5°
Calibrated temperature range	20-30°C
Minimal measuring distance	300µm
Mechanical	
Housing	Rugged lightweight housing with easy mounting option
Cable length	up to 1.5m
Total weight	~100 g
Operation temperature range	10°C-40°C, fanless operation

DIMENSIONS:

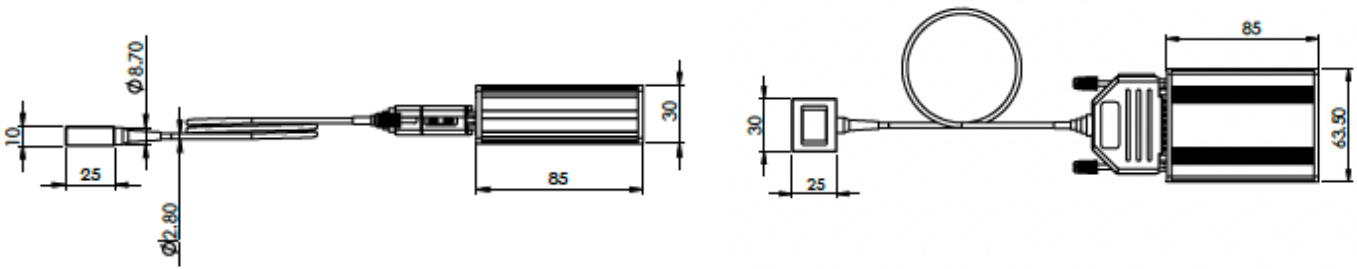

Figure 4: Structure and dimensions of the SEN-3D-CAM-CBL

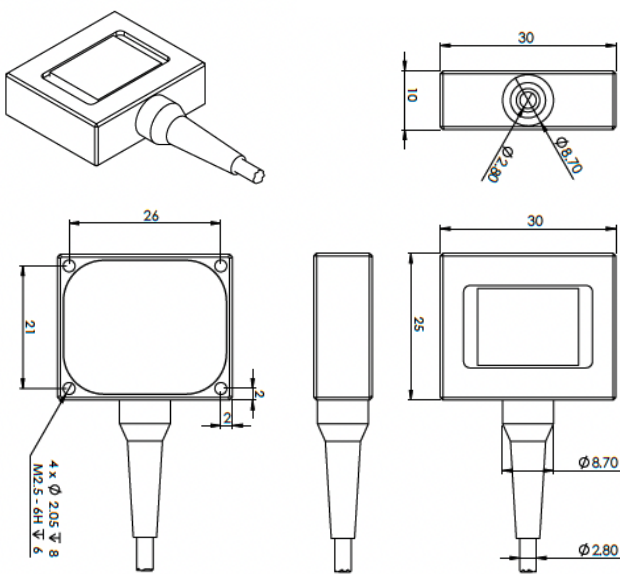

Figure 5: Dimensions of the SEN-3D-CAM-CBL head

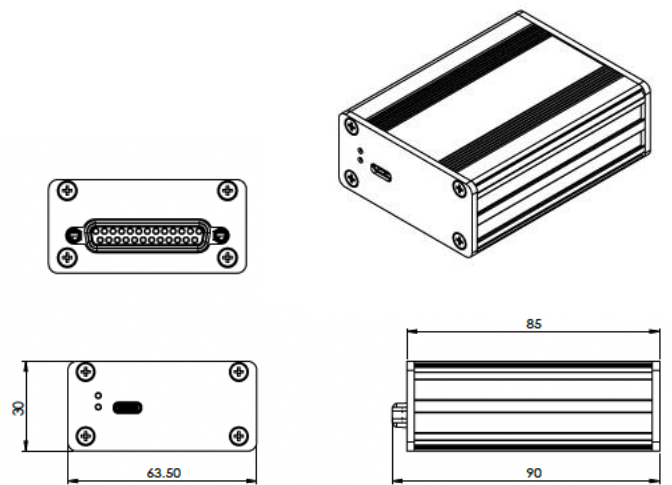

Figure 6: Dimensions of the SEN-3D-CAM-CBL electronics box

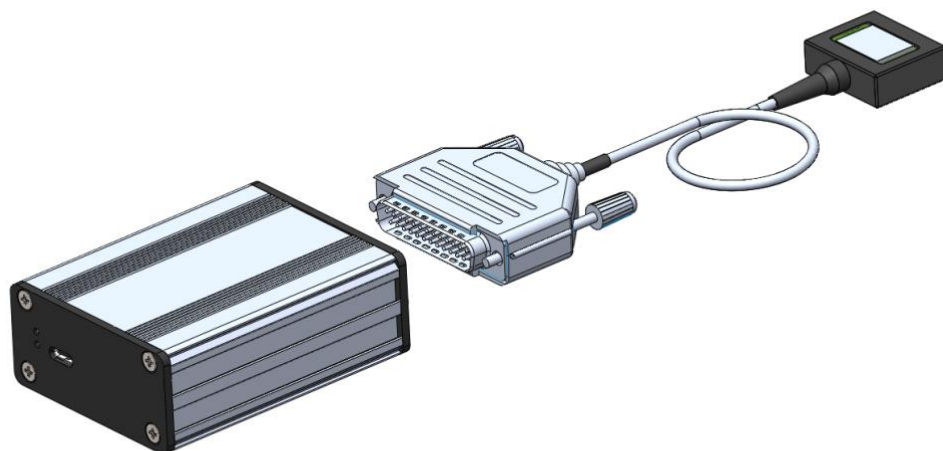

Figure 7: Structure of the SEN-3D-CAM-CBL